



K2 C | CV
K2 CR | CVR



K2 C | CV

K2 CR | CVR

SPECIFICHE TECNICHE

TECHNICAL SPECIFICATIONS

TECHNISCHE DATEN

CARACTERISTIQUES TECHNIQUES

MULINO A MARTELLI
IMPACT CRUSHER
PRALLBRECHER
CONCASSEURS À PERCUSSION

TRAMOGGIA DI CARICO
FEED HOPPER
AUFGABEBUNKER
TRÉMIE ALIMENTATION

ALIMENTATORE VIBRANTE
A BARROTTI VERSIONE "C"
GRIZZLY FEEDER "C" VERSION
STANGENVIBRATIONSAUFGEBER
VERSION "C"
SCALPEUR VIBRANT VERSION "C"

VAGLIO VIBRANTE A 2 PIANI
VERSIONE "CV"
DOUBLE DECK VIBRATING
SCREEN "CV" VERSION
ZWEI DECKEN VIBRATIONSSIEB
VERSION "CV"
CRIBLE VIBRANT A DEUX ÉTAGES
VIBRANT VERSION "CV"

NASTRO TRASPORTATORE
PRINCIPALE
MAIN BELT CONVEYOR
HAUPTFÖRDERBAND
TRANSPORTEUR PRINCIPAL

CINGOLI
TRACKS
RAUPENFAHRWERK
CHENILLES



K2 2.000 x 3.970 mm - 4 m³
K2R 2.400 x 4.570 mm - 5.5 m³

K2 970 x 3.600 mm
K2R 970 x 4.000 mm

1.020 x 2.000 mm

1.000 x 11.250 mm

450 x 3.800 mm

PESO (SENZA OPTIONALS)
WEIGHT
GEWICHT
POIDS

DIMENSIONI DI TRASPORTO
TRANSPORT DIMENSIONS
TRANSPORTABMESSUNGEN
DIMENSIONS DE TRANSPORT

IMPIANTO ABBATTIMENTO POLVERI
DUST SUPPRESSION SYSTEM
STAUBABSAUGUNG
ABATTAGE DE POUSSIÈRE

POMPA TRAVASO GASOLIO
DIESEL TANK FILLING PUMP
DIESEL OLBEHALTERFULLPUMPE
POMPE DE REMPLISSAGE RÉSERVOIR
DE GASOIL

SEPARATORE MAGNETICO
MAGNETIC BAND SEPARATOR
MAGNETABSCHIEDER
SÉPARATEUR

K2 37.000 Kg C - 37.500 Kg CV
K2R 47.000 Kg

K2 13.820 x 3.400 x 2.550 mm
K2R 17.060 x 3.600 x 3.000 mm

K2R SISTEMA DI RICIRCOLO

Vaglio vibrante ad un piano
1.500 x 3.500 mm
Nastro trasportatore estrattore
sopra vaglio
Nastro trasportatore sotto vaglio
Nastro trasportatore brandeggiante
di ricircolo

K2R RE-CIRCULATING SCREENING SYSTEM

Single deck vibrating screen
1.500 x 3.500 mm
Side transfert conveyor
Collection conveyor
Re-circulating conveyor

K2R KREISLAUFSYSTEM

Ein Deck Siebmaschine
1.500 x 3.500 mm
Austragförderband oben Siebmaschine
Förderband unter Siebmaschine
Schwenkbar förderband für Kreislauf
Rückführung

K2R SYSTÈME DE RECIRCULATION
Crible vibrant à un étage
1.500 x 3.500 mm
Conveyeur à bande dessus crible vibrant
Conveyeur à bande sous crible vibrant
Conveyeur à bande pivotant
de recirculation

OPTIONAL

RADIOCOMANDO LIV.1 - LIV.2
RADIO REMOTE CONTROL
FERNSTEUERUNG
COMMANDE À DISTANCE

NASTRO LATERALE
SIDE BELT CONVEYOR
SEITENAUSTRAGSFÖRDERER
BANDE TRANSPORTEUSE LATÉRALE
600 x 4.500 mm

POMPA PER IMPIANTO
ABBATTIMENTO POLVERI
WATER PUMP FOR DUST
SUPPRESSION SYSTEM
SELBSTANLASSENDE PUMPE
FÜR STAUBABSAUGUNG
POMPE POUR INSTALLATION
D'ABATTAGE DE POUSSIÈRE

* La produzione massima dipende dal tipo di materiale trattato e del settaggio del mulino

* The production depends of the material treatment and the C.S.S.

K2

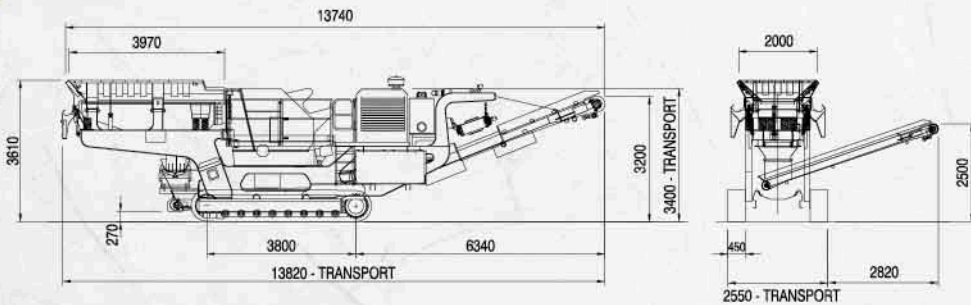

K2R

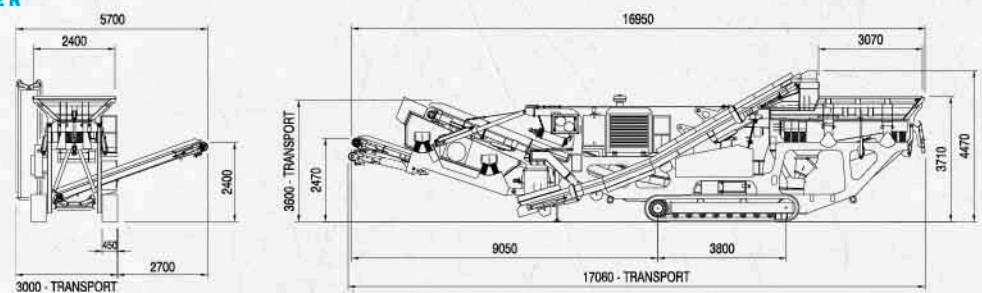

Via Giorgione, 17 - S.S. Feltrina
T +39 0423 670201
F +39 0423 676575

www.gasparin-omg.com
info@gasparin-omg.com

PRODUCTIVE UNIT
Via Palladio, 29
T +39 0423 670001
F +39 0423 670602
31040 Musano di Trevignano
(Treviso) Italy



YOUR PARTNER IN CRUSHING & SCREENING



Modifiable sans avertissement
Änderungen vorbehalten
Subject to alteration without prior notice
Documento soggetto a variazioni senza preavviso

Finestr.it - 04/2023